

Remote Cable Tester

User's Manual

NETWORKING THE FUTURE

Content

Introduction	II
Chapter 1– General Features	1
General Feature of Remote Cable Tester	1
LED Panel	2
Jack Panel.....	2
Chapter 2 – Getting Started	3
Operation Instruction	3
Application.....	4
Key Components	5
Chapter 3 – How To Read The Results ..	6
Test cables with	
RJ-45, RJ-11, USB, and BNC	6
Test cables with BNC connector.....	8
Appendix A	9
LED Indicators	9
Appendix B	11
UTP Color Code.....	11
Wiring Scheme.....	11
Specifications	12

Chapter 1 – General Features

General Feature of Remote Cable Tester

- Multiple functions:
 1. Open/Short wiring test.
 2. Connected wires display.
 3. No wire or termination indication.
 4. Wrong connection/Non-parallel connection.
 5. Ethernet 10BASE-2/10BASE-5 termination value detection.
- Four types of connector for testing today's most popular cabling systems:
 - RJ-45** for testing USOC 4/6/8, Ethernet 10BASE-T, EIA/TIA-568B, AT&T 258A, Token Ring, and any other cabling systems with RJ-45 connectors.
 - RJ-11** for testing Telephone, PhoneNet, and any other cabling systems with RJ-11 connectors.
 - USB** for testing USB, and any other cabling systems with USB connectors.
 - BNC** for testing Ethernet 10BASE-2/10BASE-5 terminator value.

Introduction

Remote Cable Tester is a palm-sized unit with four kinds of connectors: RJ-45, RJ-11, USB, and BNC, for the testing of today's most popular media. This unit can be used to verify the condition of cables, both before and after their installation. The separable passive module is connected to the remote end of installed network cabling.

The tester also offers easy operation; the user begins testing by simply pushing a button. Multiple LEDs give a clear indication of testing status and go off automatically, to maximize power saving.

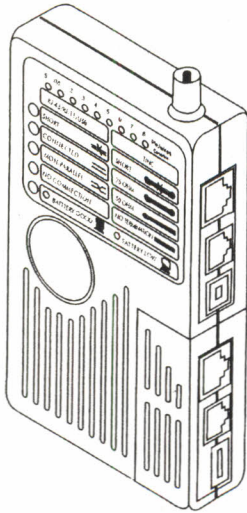

Chapter 1

- Remote module design for testing two remote points
- Simple operation step
- Power supplied with battery
- Automatic de-activation for power saving.
- Battery condition indicator.

LED PANEL

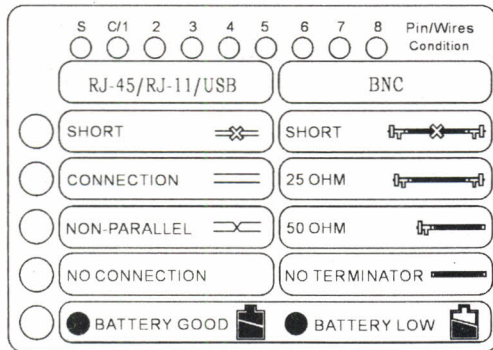

Jack Panel

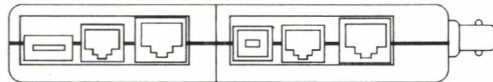

Chapter 2 – Getting Started

Chapter 2 –Getting Started

Operation Instruction

To test the cable not installed(RJ-45,RJ-11,USB, and BNC):

- 1.Connect cable's one end to the master's proper connector,and the other end to the remote module.
- 2.Press the test button.
- 3.Read the result when the LEDs stop flashing.

To test the cables already installed(RJ-45,RJ-11, USB,and BNC):

- 1.Connect cable's one end to the master's proper connector.
- 2.Separate the remote module,then connect to the cable's remote point.
- 3.press the test button.
- 4.Read the result when the LEDs stop flashing.

Note 1: Do not connect the tester to a live circuit.

Note 2: Do not test more than one cable simultaneously.

Chapter 2

To test Ethernet 10BASE-2/10BASE-5 terminator value(BNC)

1. Disconnect any one of the T-connectors from its attached node on the 10BASE-2 segment that you want to test, and link the T-connector with the tester's BNC port.
2. Press the test button.
3. Read the result when the LED stop flashing.

Note 1: Before conducting the test, verify there isn't any activities on the 10BASE-2 segment.

Note 2: If testing LED fails to light on after pressing the test button, replace battery.

Application

Who can benefit from the Remote Cable Tester?

- Network cabling system installer
- Telephone cabling system installer
- Network debugging technician
- Cable manufacturer

Chapter 2- Getting Started

Key Components

Remote Tester Master Unit

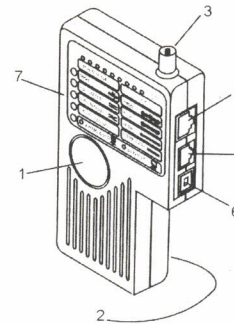

- 1 Operation push button
- 2 Battery cover(on the back).
- 3 BNC connector
- 4 Shielded RJ-45 connector
- 5 RJ-11 connector
- 6 USB B connector
- 7 LED indicators(Refer to Appendix A)

Remote Module

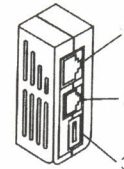

- 1 Shield RJ-45 connector
- 2 RJ-11 connector
- 3 USB A connector

Chapter 3 – How To Read The Results

Here are some examples of how to read the testing results.

Testing RJ-45,RJ-11,USB,and BNC

Short Test

When LEDs for **Short,S**,and **3** are on and the tester beeps four times,it means Wire number **3,4**,and **5** are short.

Connected Test

When LEDs for **Connected,S**,and **1...8** LED are on and the tester beeps three times, it means the shielding and indicated wires are pin-to-pin connected between cable's two ends.For instance,if a standard Ethernet 10BASE-T unshielded,twisted -paired cable (UTP)are tested,the LEDs for **Connected, wire 1,2,3**,and **6** will turn on.

Note:If there is only one wire connected inside a cable between the cable's two ends,the tester will state no wire connected.

Chapter 3

Connected & Non-parallel Test

LEDs for both **Connected and Non-parallel**, and LEDs for **Wire S,1,2,...8** turn on and the tester beeps twice,it means the shielding and indicated wires are connected between cable's two ends,but not pin-to-pin straight connection. It is possibly a wrong connection cable,or a cross-over cable.

Note : If there are only two wires connected inside a cable between the cable's two ends, the tester cannot detect whether these two wires are pin-to-pin connected or not.It only indicates two wired connected.

No Connection Test

When the **No Connection** LED turns on and the tester beep once,it means there is no connection between the master and the rernote module.It happens when no cable is connected with the tester.

Chapter 3- How to read the results

Testing BNC connector

LED for short, S, and C

When LEDs for **Short, S,** and **C** turn on and beeps four times, it means the shield and the center of BNC connector is short.

LED for 25 OHM, S, and C

When LEDs for **25 OHM, S,** and **C** turn on and the tester beeps three times, it means tested cable is terminated with correct terminated resistor Value.

LED for 50 OHM, S, and C

When LEDs for **50 OHM, S,** and **C** turn on and the tester beeps twice, it means a single ending terminated resistor value is detected. it may be caused by a broken cable, or the terminator at one end is not linked well.

LED for No Terminator

When LED for **No Terminator** turns on and the tester beeps once, it means no resistor value detected between shielding and center. The cable is probably not terminated (all open.)

Appendix A-LED indicators

Appendix A-LED indicators

The Remote Cable Tester has totally 14 LEDs, 9 in horizontal indicating each individual wire inside a cable, 5 in vertical telling a cable connection status. You can read the result from the combination of lit horizontal and vertical LEDs

- **S(YELLOW)**
Shielding
- **C/1(YELLOW)**
Center of coaxial cable (BNC) or wire 1 of TP cable (RJ-45), telephone cord (RJ-11), or USB
- **2,3,4,...8(YELLOW)**
Wire 2,3,4,...8
- **SHORT (RED)**
Short condition between wires, or between shielding and center of BNC connector/cable are detected.
- **CONNECTED or 25 OHM(GREEN)**
A straight-through connection cable is detected. Or a standard Ethernet 10BASE-2 and 10-BASE-5 terminated with 25 OHM cable is detected.
- **NON-PARALLEL or 50 OHM**
A non-straight-through connection cable is detected. Or an Ethernet 10BASE-2 and 10BASE-5 cable with one end termination value (50 OHM) is detected.

Appendix A

- **No CONNECTION/NO TERMINATOR (YELLOW)**

No cable or terminator is scanned.

- **BATTERY GOOD/BATTERY LOW(YELLOW/GREEN)**

It shows the battery status. If green displayed, meaning the battery condition is good while if yellow displayed, indicating the battery condition is low. Replace the old battery with a new one when LED fails to remain lit during normal operation.

Appendix B – UTP Color Code

Appendix B

UTP Color Code

Pair 1	White-Blue(W-BL) Blue(BL)
Pair 2	White-Orange(W-O) Orange(O)
Pair 3	White-Green(W-G) Green(G)
Pair 4	White-Brown(W-BR) Brown(BR)

Wiring Scheme

T568A	T568B
1 W-G	1 W-O
2 G	2 O
3 W-O	3 W-G
4 BL	4 BL
5 W-BL	5 W-BL
6 O	6 G
7 W-BR	7 W-BR
8 BR	8 BR

Specifications

Function:

- Open/Short wiring test
- Connected wires display
- NO connection/no terminator indication
- Wrong connection/Non-parallel connection display
- Ethernet 10BASE-2/10BASE-5 terminator value detection

Indicators:

- BATTERY GOOD/BATTERY LOW (GREEN/YELLOW)
- NO CONNECTION/NO TERMINATOR LED (YELLOW)
- NON-PARALLEL/50 OHM LED (YELLOW)
- CONNECTED/25 OHM LED (GREEN)
- SHORT LED (RED)
- S,C/1,2,3,4,5,6,7,8 LEDs (YELLOW)

Connectors:

- RJ-45 × 2
- RJ-11 × 2
- USB A × 1
- USB B × 1
- BNC × 1

Cable length:	200m for all connectors
Power:	9-Volt Alkaline Battery
Size:	145 × 86 × 26mm 5.708 × 3.386 × 1.024 inch
Weight:	185g/6.53oz